

Estonian national Group E 4WD technical regulations

Approved by EASU 15.12.2021

1. Definition

- 1.1. All the cars must be either, Gr A and Gr N with expired homologation, or non-homologated series production cars available through normal sale channels. Non-homologated cars must comply with Articles 251 and 253 of FIA Appendix J. WRC cars are prohibited.
- 1.2. Cars allowed to compete only in classes with engine over 2000 cm³
- 1.3. Homologation date of the national Group E car is considered as the date of the issuing technical card to specific competition car.
- 1.4. Safety cage must comply to FIA Appendix J Art.253.8. valid at the time of issuing the technical card.
- 1.5. All additions, modifications, and solutions of which is by the scrutineers deemed to be dangerous, is considered dangerous. Any additional questions contact EASU technical commission tehniline@autosport.ee

2. Weight

Minimum weight according to their cubic capacity:

2000 cm ³ up to 2500 cm ³	1080 kg
over 2500 cm ³ up to 3000 cm ³	1150 kg
over 3000 cm ³ up to 3500 cm ³	1230 kg
over 3500 cm ³ up to 4000 cm ³	1310 kg
over 4000 cm ³ up to 4500 cm ³	1400 kg
over 4500 cm ³ up to 5000 cm ³	1500 kg
over 5000 cm ³ up to 5500 cm ³	1590 kg
over 5500 cm ³	1680 kg

Real weight of the car is considered weight without neither driver nor co-driver nor their equipment and with a maximum of one spare wheel. Weight of the car according to Group A regulations or homologation. At no time during the competition may a car weigh less than this minimum weight.

3. Authorized modifications and adjunctions

3.1. Engine

All modifications not prescribed here must comply with Group A regulations of FIA Appendix J Art. 255 chapters 1 up to 5.9.3.

3.1.1. Engine type and manufacturer are free. Location of the engine in its original compartment is free. Mounting points can be added. Necessary modifications to bodywork to accommodate engine auxiliaries are permitted.

3.1.2. In case of supercharging, the nominal cylinder capacity is multiplied by 1,7 for petrol engines and by 1,5 for diesel and rotor engines. Chemical supercharging is prohibited.

3.1.3. The maximum internal diameter of the turbo restrictor is 34 mm according to FIA Appendix J Art 255 drawing 254-4, applies also only to Group N homologated cars.

3.1.4. Cylinder head is free.

3.1.5. Lubrication system is free. Location of the oil radiator in engine compartment is free. Oil radiator cannot be fitted inside cockpit.

3.1.6. Radiator and its location in engine compartment is free

3.1.7. Intercooler and its location in engine compartment is free

3.1.8. Radiators cannot be mounted inside of the cockpit.

3.2. Transmission

3.2.1. Gearbox is free with following restrictions:

- number of mounting points must be retained
- to change the location of the gear level modifications to the bodywork is allowed.
- only mechanical gearbox operated by driver mechanically is allowed
- gearbox must include reverse gear

3.2.2. Clutch is free.

3.2.3. Drive shafts are free, provided no composite materials is used.

3.3. Suspension

3.3.1. Suspension and its components are free, provided its operation type is maintained and car is driveable if modified parts replaceable with originals.

3.3.2. Number of shock absorbers must be retained.

3.3.3. Suspension and shock absorbers adjustable during the driving are forbidden.

3.4. Bodywork, bodyshell, chassis

3.4.1. Bonnet, boot lid, rear doors, mudguards, spoilers, bumpers with additions can be made from other materials (metal, composite, plastic), but car's overall width cannot be widened more than 70 mm.

3.4.2. Windows can be made from plastic, except windscreen. Plastic windows must be made from unbreakable material (bendable without breaking) with minimal thickness 3,0 mm. Plastic front side windows must have a sliding hatch with min measures 140x140 mm, or revolving hatch with diameter min 140 mm. Plastic side windows must be mounted to the bodywork by means of glueing and/or riveting, max diameter of rivets 3,2 mm. Although plastic windows can be mounted into original seals. In this case windows must be fixed from bottom to the door frame with two mounting points. For cars without a window frame on the doors, it is permitted to use plastic windows if the doors are fitted with a frame made of metal tube (min. 10x10 mm) following the original window opening.

3.5. Brakes

3.5.1. Pedal box is allowed, but at least dual circuit brakes are compulsory.

Non-homologated anti-lock brake systems are prohibited.

3.5.2. Air channel for cooling the brakes must be with max diameter 100 mm.

3.5.3. Only series production components can be used

3.5.4. Otherwise the braking system is free.

3.6. Electrical system

3.6.1. Battery is free. Nominal voltage must be retained.

3.6.2. Should the battery be moved from its original position, only dry battery can be used and it must be fastened to the body with at least 2 metal rods with at least M6 bolts. Attachment points must be strengthened with 3 mm thick metal plates with an area of 20 cm².

3.7. Fuel tank

3.7.1. Original fuel tank can be replaced with FIA FT3 1999; FT3.5; FT5 and also SFI safety fuel tank, and also with other autosport intended safety tanks with following information:

- name of the manufacturer
- model and the series numbers
- the date of the end of validity

3.7.2. Safety fuel tanks may be used another two years after the date of the end of validity.

3.7.3. Safety fuel tank must be located behind of the main rollbar and separated from cockpit with leak-proof and non-flammable cover or container. If the FIA standardised connectors not used, filler neck must be fitted to external surface of the car. The fuel tank air vent(s) must be equipped with non return and closing valves.

4. Safety cage

4.1. Safety cages according to FIA Appendix J, Art.8.

4.2. Safety cage must comply to FIA Appendix J Art.253.8. valid at the time of issuing the technical card.

4.3. Inside the cockpit, the passage of any lines between the side members of the bodyshell and the safety cage is forbidden.

4.4. It is allowed to use 8857-2001 Type A homologated paddings (FIA Technical List no 23), but also other safety cage paddings, which are made from non-flammable material with minimum thickness 15 mm.

5. Drivers safety equipment

5.1. Drivers safety equipment according FIA Appendix L, Art III

5.2. Fire extinguishing system is compulsory, according to FIA Technical Lists no 16 or no 52 and instructions of the manufacturer.

5.3. Seats must be must be homologated at least by the FIA standard 8855-1999 and may be used after their expiry date, provided that their framework is not deformed, supports not detached and that there are no significant damage or tears in the cover fabric.

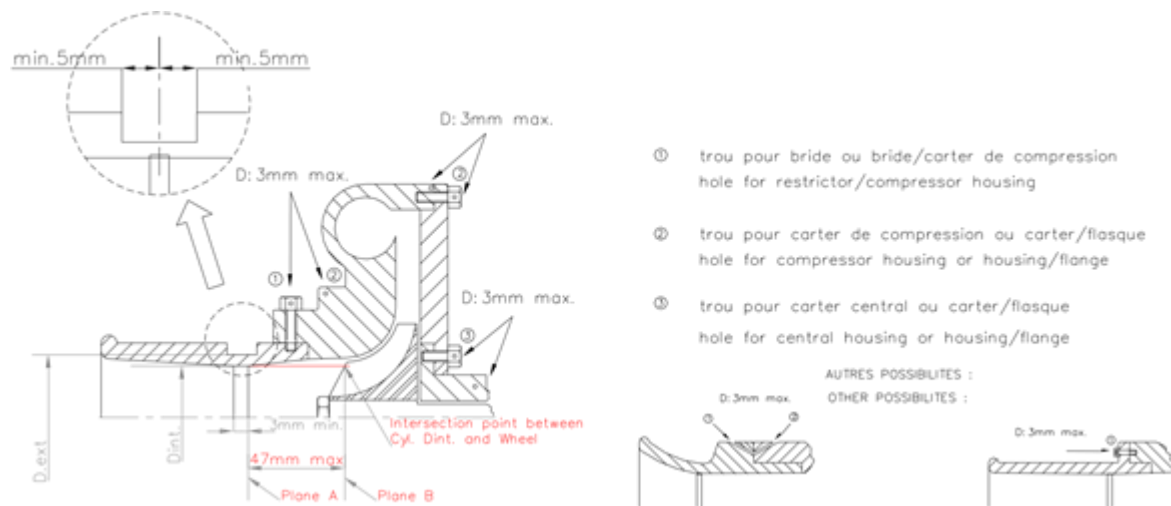

Drawing 254-4